

SRX 14-16

ELECTRIC REACH TRUCK 48 VOLT
1400 / 1600 kg
2800 / 3200 lbs.



CLARK[®]
THE FORKLIFT

High Capacities at High Lift Heights

- Robust construction and stability.
- Nested I-sectioned mast.
- Upright rails with I-section design have 55% greater torsional rigidity than conventional flat rails.
- Less distortion even with lateral forces.

Result:
Improved durability and stability – even with high lift heights.

Optimum Visibility

- Overhead guard & visibility through the upright.
- The overhead guard safety bars run parallel to the operator's line of vision.
- Optimum visibility through the upright thanks to wide-spaced rails and centre cylinder rotated to side.

Upright Cushioning

- Smooth load transport.
- Smooth lifting and lowering thanks to integrated hydraulic damping system.
- Smooth transitions between upright stages.
- No loud bumps when lowering.
- Increased component durability.

Wear-Free Support Arm Brakes

- Increased safety in standard configuration.
- Two maintenance-free support arm brakes assist all braking operations.
- No service required – unlike drum brakes.

- Compact design: the SRX series can be used to handle euro pallets in aisle widths from 2,731 mm.

Sturdy, Reliable and Powerful Even in Tough Applications

The CLARK SRX14-16 series has been designed to satisfy the most demanding requirements. With a large number of options, including a fork camera and automatic horizontal fork positioning, you will be sure to find the right truck to meet the specific requirements of your operation.



Maximum Visibility + Ergonomic Operator Compartment =
High Productivity & Maximum Safety



Why Support Arm Brakes?

- Shorter braking distance = greater safety
- At driving speeds of up to 14 km/h in the warehouse, the ability to decelerate rapidly can be a major advantage in terms of safety and the rapid handling of goods
- CLARK SRX reach trucks feature two electric support arm brakes

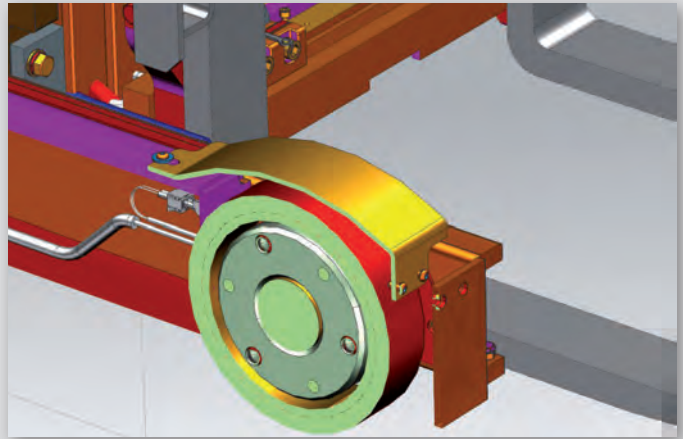

with support arm brakes

Up to 20% shorter braking distance with support arms brakes as standard



**B R A K I N G
D I S T A N C E**

without support arm brakes

Wear-Free Electric Support Arm Brakes + Upright Cushioning = Lower Total Cost of Ownership (TCO) & Greater Safety



Improved Ergonomics & Performance

- Fork camera with screen.

Increased Safety as Standard

- Two wear-free support arm brakes assist braking operations.
- Support arm rollers have protective wheel covers as standard.

SRX14-16 ERGONOMICS & COCKPIT

Safety

- Extensive safety equipment.
- Fused circuits.
- Load wheel brakes as standard.
- Additional assistance systems.

Operator Compartment

- Full-suspension comfort seat.
- Individually adjustable for all operators.
- Low entry height thanks to foot step (380 mm).
- 3 adjustable drive modes (Ergonomic/ Normal/ Power).

Intuitive Operation

- Mini-levers or mono-joystick.
- Simultaneous control of hydraulic function.
- Automotive pedal layout.
- 180° or 360° steering.
- Smallest possible turning radius or rapid change of direction.
- Speed control when cornering.
- Spacious compartment and excellent visibility.



Reliability

- Traditional CLARK durability and reliability.
- 100 years' experience.
- All components meet our high standards of quality and reliability.

Robust Construction

- Solid steel chassis for maximum strength and durability.
- Low load centre.
- Protected support arm rollers.
- Excellent stability and outstanding residual capacities of 1,000 kg up to 10 metres lift height.

Maintenance & Service

- Maintenance-free AC technology.
- Enclosed design (IP43).
- Overheat protection.
- Vehicle diagnostics via dash display.
- All service points easily accessible.

High Performance Guaranteed

- 100% AC system.
- Battery capacity 465/620 or 775 Ah.

CLARK Mono-Joystick

- **Maximum Throughput Rate**
 - All upright functions integrated in one joystick.
 - Precise and responsive.
 - 100% proportional lifting and lowering.
 - Ergonomic armrest.
 - Best choice for maximum throughput rate.



Multi-Function Display

- **All Settings and Functions at a Glance**
 - Clear multi-colour display.
 - 3 selectable drive modes (individually adjustable).
 - Steering angle and travel direction indicator.
 - Battery charge indicator.
 - Load weight indicator.
 - Travel speed display.



OPTIONS

Automatic Horizontal Fork Positioning

- Especially suited for high lift heights.
- No need for unreliable estimates of fork tilt.

Lift Height Preselector

- Forks stop automatically at desired lift height.
- Increased throughput rate thanks to quicker positioning.
- Reduced damage to goods or shelving.

Fork Camera & Monitor

- Improved ergonomics & throughput rate.
- No need to look up to see goods.
- Quicker access to high shelving units.
- Significant reduction of operator fatigue.

Battery Compartment Sizes

- Optimum size for every application.
- 3 capacities to select (465/620/775 Ah).
- Lateral battery extraction as standard.

Activation via PIN Code

- Keyless activation via four-digit PIN.
- Automatic shut-down setting.
- Driving characteristics individually programmable for each PIN.

Automatic Side Shift Centring

- Easy and safe handling.
- Quicker positioning at the shelf.

Fork Positioner

- Easy positioning of pallet cages and different-sized loads.
- Quicker transport of goods with different dimensions.



Dependable Parts = Dependable Trucks



The CLARK PartsPRO® Plus System

is our industry-leading electronic parts and service documentation tool that provides dealers with a quick and accurate method of identifying parts for every CLARK forklift built since 1961. PartsPRO® Plus ensures the availability of the most current technical information and has the unique capability to create parts manuals specific to your mixed CLARK fleet, making it simple to positively identify and order the correct part(s) from your local CLARK dealer. The right CLARK part - The First Time, Every Time.



Note: "Photos and illustrations are based on information at the time of printing and are subject to change without notice. Some products may be shown with optional equipment. Model assumption detail variations are possible."

Официальный дилер: ООО «Форклифт»

Тел./факс: (499) 951-79-99 (многоканальный)

Екатеринбург: (343) 344-00-22; Пермь: (342) 294-40-49

Челябинск: (351) 211-54-25; Тюмень: (345) 238-28-26

E-mail: sales@forklift.ru, Web: www.forklift.ru

Skype: forklift-ural

BUILT TO LAST.®



CLARK EUROPE GmbH

Dr.-Alfred-Herrhausen-Allee 33 · 47228 Duisburg / Germany
Tel: +49 (0)2065 499 13-0 · Fax: +49 (0)2065 499 13-290
Info-europe@clarkmheu.com · www.clarkmheu.com

4580186

SRX14-16

Dealer: