

Characteristics		Clark C RT 20 ac	
1.1	Manufacturer	Clark	
1.2	Manufacturer's model designation	C RT 20 ac	
	T = integrated side-shift	T	
1.3	Drive : E ( electric )	E	
1.4	Type of control : S (steering wheel) R (seated)	S / R	
1.5	Load capacity	Q ( t )	2.0
1.6	Load centre distance	c ( mm )	600
1.8	Load distance, centre of drive axle to fork	X ( mm )	375
	Mast advanced	X1 ( mm )	220
1.9	Wheelbase	Y ( mm )	1.470
Weights			
2.1	Service weight ( battery included )	Kg	3.840
2.3	Axle loading mast retracted ( without load )	front / rear	2.452 / 1.388
2.4	Axle loading mast advanced ( with load )	front / rear	675 / 5.165
2.5	Axle loading mast retracted ( with load )	front / rear	2.215 / 3.625
Wheels - Chassis			
3.1	Tyres : vIk ( vulkollan ) se ( superelastic )	vIk	
3.2	Front wheels size	mm	343
3.3	Rear wheels size	mm	350
3.5	Wheels : number front / rear ( x = traction )	1x / 2	
3.7	Rear track width	b 11 ( mm )	1.182
Dimensions			
4.1	Mast / fork carriage tilted forward / backward	a / b	3 / 5
4.2	Lowered mast height	h1 ( mm )	2.655
4.3	Free lift	h5 ( mm )	2.130
4.4	Lifting height	h3 ( mm )	5.965
4.5	Extended mast height	h4 ( mm )	6.620
4.7	Overhead guard ( cab ) height	h6 ( mm )	2.100
4.8	Seat height	h7 ( mm )	1.050
4.10	Height of wheels arm	h8 ( mm )	225
4.19	Total length	l1 ( mm )	2.520
4.20	Length to forks face	l2 ( mm )	1.370
4.21	Overall width	b1 / b2 ( mm )	1.270
4.22	Forks dimensions	s / e / l	40 / 120 / 1.150
4.23	Fork carriage, class / type A, B	II A	
4.24	Fork carriage width	b5 ( mm )	840
4.25	Width over forks	b3 ( mm )	720
4.26	Distance between support arms / loading surfaces	b4 ( mm )	948
4.28	Reach distance	l4 ( mm )	595
4.32	Ground clearance	laden	m2 ( mm ) 75
4.33	Aisle width with pallets 1000 x 1200 forking side 1200	Ast3 ( mm ) 2.820	
4.34	Aisle width with pallets 800 x 1200 forking side 800	Ast3 ( mm ) 2.870	
4.35	Turning radius	Wa ( mm ) 1.746	
4.37	Length across wheel arms	l7 ( mm ) 1.950	
Performances			
5.1	Travel speed	laden / unladen	Km / h 13 / 13
5.2	Lifting speed	laden / unladen	m / s 0.35 / 0.5
5.3	Lowering speed	laden / unladen	m / s 0.5 / 0.45
5.7	Gradient performance	%	
5.8	Max gradient performance	%	
5.9	Acceleration time ( 10 m )	s 6 / 5.6	
5.10	Service brake M (mechanical) I (hydraulic) IV (inversion braking) E (electromagnetic)	I / E	
El. motor			
6.1	Traction motor, rating S2 60 min	KW	6.5
6.2	Lifting motor, rating S3 15%	KW	15
6.3	Battery according DIN 43531 / 35 / 36 A, B, C, no	no	
6.4	Battery voltage, nominal capacity K5	V / Ah	48 / 620
6.5	Battery weight ( ± 5 % )	Kg	950
	Battery dimensions l / w / h	L/W/H mm	1.220 / 346 / 770
Others			
8.1	Type of travel control	INVERTER	
8.2	Operating pressure for attachments	bar	180
8.3	Oil volume for attachments ( max available )	l / min	25
8.4	Sound level at driver's ear	dB ( A )	< 70
Technical specification according VDI 2198			DS.091EN.REV.00
All values shown are for standard lift truck with standard equipment. If the truck is supplied with options, values may change. All values given may vary +5% and -10% due the motor and system tolerances and represent nominal values obtained under typical operating conditions.			

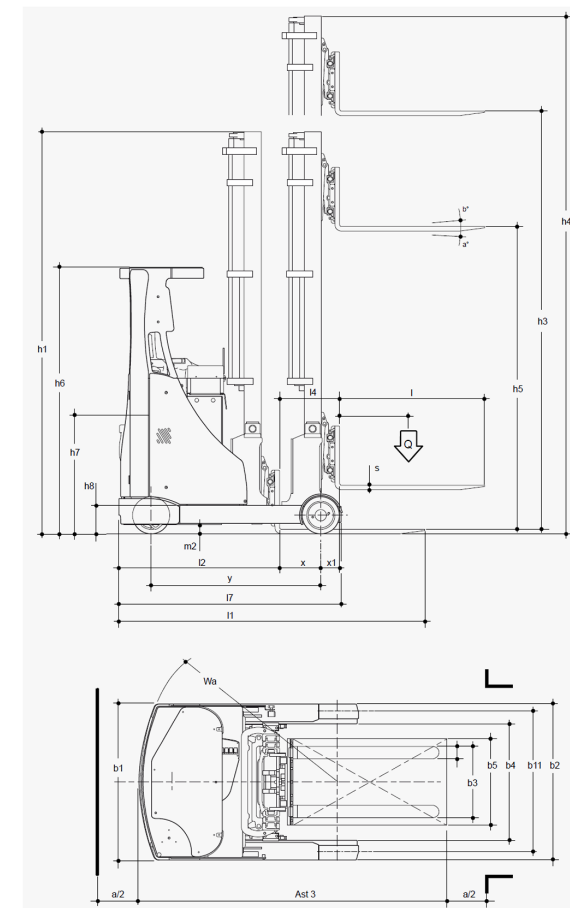

	h3		h1	h4	h5	(Q) t
4.165 tx	mm		2.045	4.820	1.470	2.0
4.465 tx	mm		2.145	5.120	1.575	2.0
5.165 tx	mm		2.390	5.820	1.810	1.9
5.965 tx	mm		2.655	6.620	2.130	1.75
6.665 tx	mm		2.925	7.320	2.360	1.5
7.465 tx	mm		3.185	8.120	2.630	1.4
8.215 tx	mm		3.480	8.870	2.930	1.1
8.965 tx	mm		3.825	9.620	3.280	1.08
9.460 tx	mm		3.900	10.120	3.350	0.90
10.460 tx	mm		4.230	11.120	3.680	0.80