

C 60/70/80D

C 60/70/75L

Diesel or LPG engine

Pneumatic or Superelastic Tyres

6.000 kg 7.000 kg 7.500 kg 8.000 kg

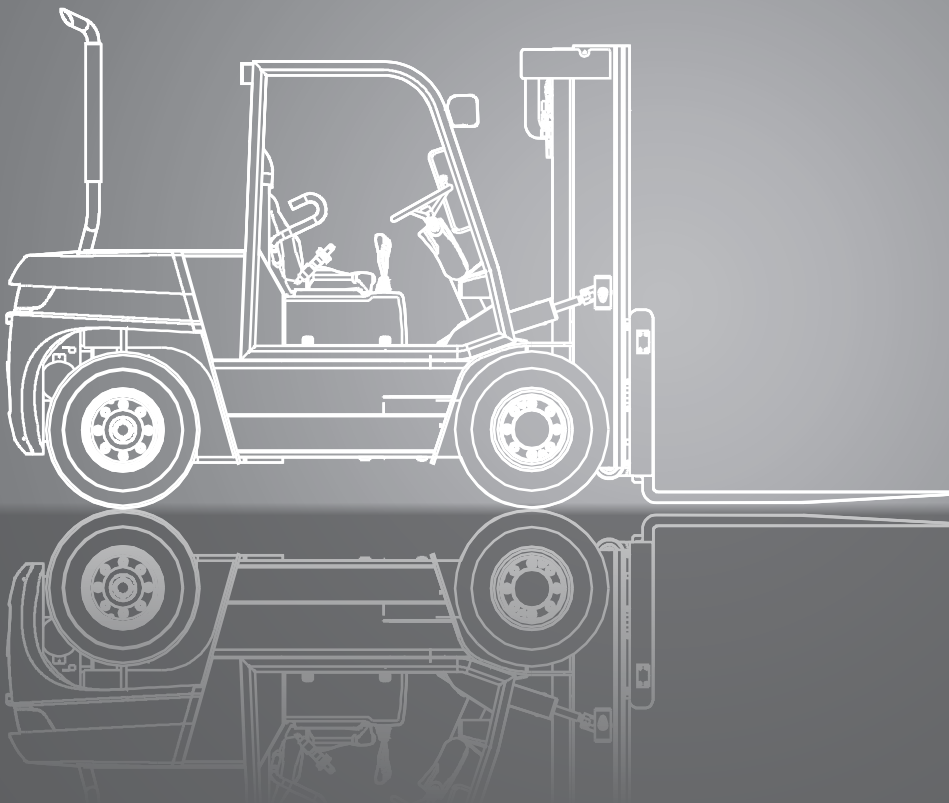

Diesel Engine
Emission Level: Stage 3a

DIMENSIONS

C60/80

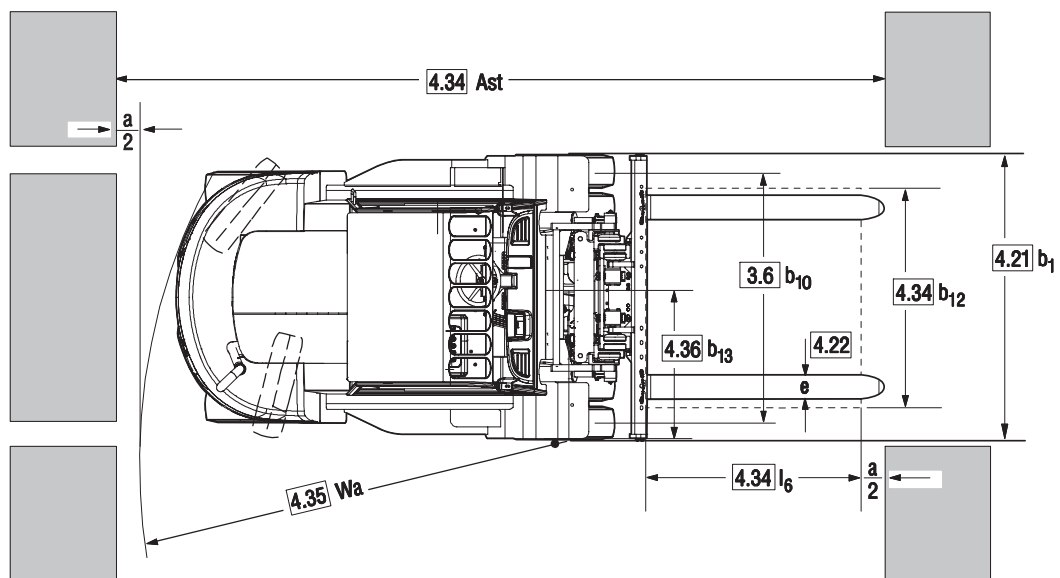
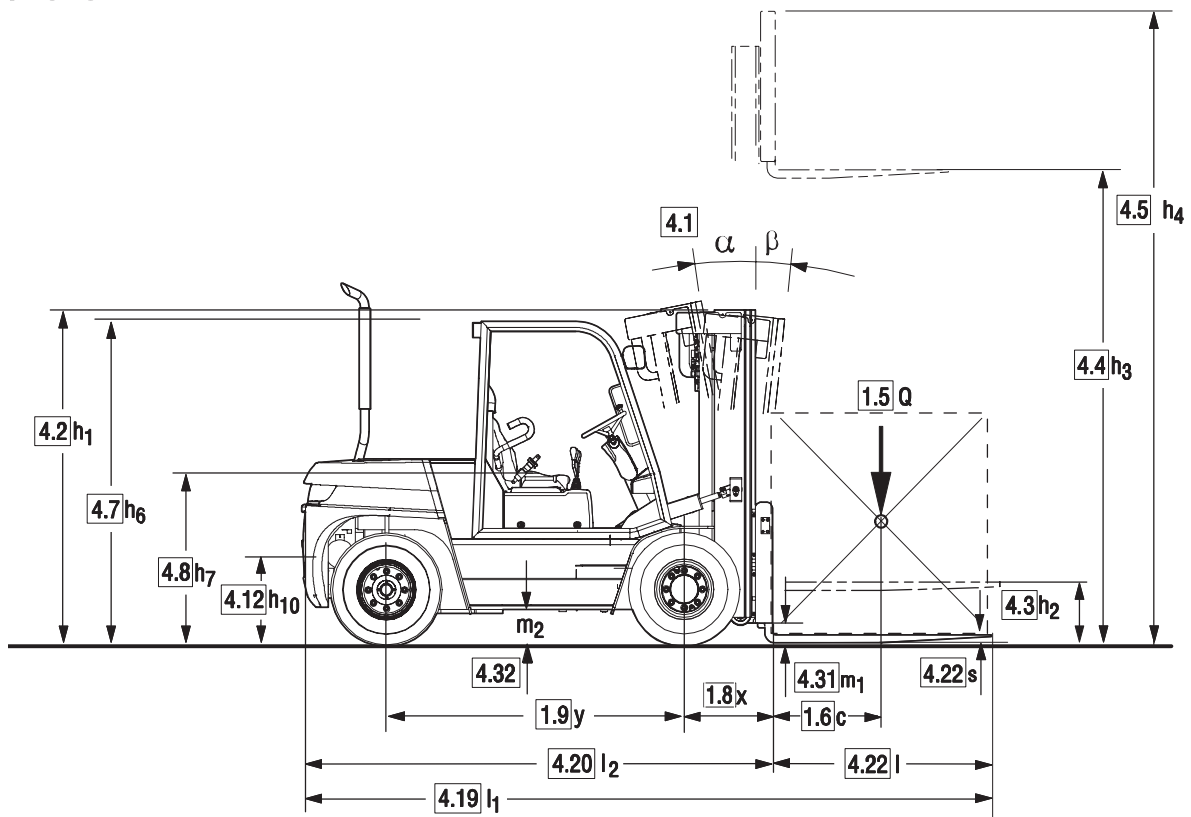

$$l_{st} = Wa + x + l_6 + a$$

$$\text{plies only if } \frac{b_{12}}{2} < b_{13}$$

$$l_{st} = Wa + \sqrt{(l_6 + x)^2 + \left(\frac{b_{12}}{2} - b_{13}\right)^2} + a$$

$$\text{plies only if } \frac{b_{12}}{2} \geq b_{13}$$

$$= 200$$

SPECIFICATIONS

Product Specifications acc. to VDI 2198

1.1 Manufacturer (Abbreviation)		CLARK	CLARK	CLARK
Specifications	1.2 Manufacturer's designation	C60D	C70D	C80D
	1.3 Drive unit Diesel, L.P. Gas	Diesel	Diesel	Diesel
	1.4 Operator type stand on/ driver seated	Driver Seated	Driver Seated	Driver Seated
	1.5 Load capacity /rated load Q (kg)	6000	7000	8000
	1.6 Load centre distance c (mm)	600	600	600
	1.8 Load centre distance, centre of drive axle to fork face x (mm)	630	630	641
	1.9 Wheelbase y (mm)	2250	2250	2500
	WT	2.1 Service weight kg	9306	9676
2.2 Axle loading, laden front/rear kg		13336/1970	14758/1918	16275/2163
2.3 Axle loading, unladen front/rear kg		4071/5235	3950/5726	4263/6175
Tyres, Chassis	3.1 Tyre type, P = pneumatic, SE = superelastic 1)	P	P	P
	3.2 Tyre size, front	8.25X15-14PR	8.25X15-14PR	8.25X15-18PR
	3.3 Tyre size, rear	8.25X15-14PR	8.25X15-14PR	8.25X15-18PR
	3.5 Wheels, number front/rear (x = drive wheels)	4X/2	4X/2	4X/2
	3.6 Tread, front b10 (mm)	1575	1575	1575
	3.7 Tread, rear b11 (mm)	1610	1610	1610
	Dimensions	4.1 Tilt of upright/fork carriage, α/β Grad	10/15	10/15
4.2 Height, upright lowered h1(mm)		2650	2650	2726
4.3 Freelifth h2(mm)		110	110	233
4.4 Lift height 2) h3(mm)		3300	3300	3300
4.5 Height, upright extended 5) h4(mm)		4464	4464	4464
4.7 Height overheadguard (cab); Std/ Container h6(mm)		2370	2370	2370
4.8 Seat height h7(mm)		1320	1320	1320
4.12 Coupling height h10(mm)		470	470	470
4.19 Overall length l1(mm)		4723	4783	5095
4.20 Length to face of forks l2(mm)		3523	3583	3895
4.21 Width b1, b2 (mm)		2125	2125	2125
4.22 Fork dimensions s • e • l (mm)		60X150X1200	60X150X1200	70X180X1200
4.23 Fork carriage DIN 15173, A, B		Shaft type	Shaft type	Shaft type
4.24 Fork carriage width b3 (mm)		2040	2040	2040
4.31 Ground clearance minimum m1 (mm)		200	200	200
4.32 Ground clearance centre of wheelbase m2 (mm)		230	230	230
4.33 Aisle width for pallets 1000 x 1200 crossways Ast(mm)	5250	5280	5616	
4.34 Aisle width for pallets 800 x 1200 lengthways Ast(mm)	5450	5480	5816	
4.35 Turning radius (mm)	3420	3450	3775	
4.36 Internal turning radius b13 (mm)	1063	1063	1063	
Performances	5.1 Travel speed laden/unladen km/h	31.8/34.6	29.0/33.5	29.0/33.6
	5.2 Lift speed laden/unladen m/s	0.43/0.45	0.42/0.45	0.39/0.45
	5.3 Lowering speed laden/unladen m/s	0.45/0.43	0.45/0.43	0.45/0.43
	5.6 Max. drawbar pull laden/unladen 3) N	56989/19485	57339/18809	56682/19466
	5.8 Max. gradeability laden/unladen 3) %	41.0/21.2	37.4/19.8	33.0/19.3
	5.10 Service brake	Wet disc brake	Wet disc brake	Wet disc brake
I.C.-Engine	7.1 Manufacturer /Type 5)	IVECO/F4GE9454C	IVECO/F4GE9454C	IVECO/F4GE9454C
	7.2 Rated output acc. DIN 70 020 kW	67	67	67
	7.3 Rated speed acc. DIN 70 020 min-1	2300	2300	2300
	7.4 No. of cylinders /displacement /cm3	4/4500	4/4500	4/4500
	7.5 Fuel consumption acc. VDI-CyclusDiesel = l/h, L.P.-Gas = kg/h	-	-	-
Misc.	8.1 Type of control	Hydrodyn.	Hydrodyn.	Hydrodyn.
	8.2 Operating pressure for attachments 5) bar	Adjustable	Adjustable	Adjustable
	8.3 Oil volume for attachments l/min	max. 35	max. 35	max. 35
	8.4 Sound level, driver's ear acc. EN 12053 dB (A)	83	83	83
	8.5 Towing coupling, class/type DIN	PIN	PIN	PIN

*1 Optional with super-elastic tyres *2 Further lift heights see upright table *3 At friction coefficient $\mu = 0.6$ *4 Diesel = Stage 3a / LPG = Stage 0 *5 Max. 140 bar

Performance may vary +5% and -10% due to motor and system efficiency tolerance. The performance shown represents nominal values which may be obtained under typical operating conditions of a machine. CLARK products and specifications are subject to change without notice.

Product Specifications acc. to VDI 2198

1.1 Manufacturer (Abbreviation)		CLARK	CLARK	CLARK
Specifications	1.2 Manufacturer's designation	C60L	C70L	C75L
	1.3 Drive unit Diesel, L.P. Gas	LPG	LPG	LPG
	1.4 Operator type stand on/driver seated	Driver Seated	Driver Seated	Driver Seated
	1.5 Load capacity /rated load Q (kg)	6000	7000	7500
	1.6 Load centre distance c (mm)	600	600	600
	1.8 Load centre distance, centre of drive axle to fork face x (mm)	630	630	630
	1.9 Wheelbase y (mm)	2250	2250	2250
WT	2.1 Service weight kg	9077	9447	9590
	2.2 Axle loading, laden front/rear kg	13263/1814	14685/1762	15514/1576
	2.3 Axle loading, unladen front/rear kg	3998/5079	3877/5570	3934/5656
Tyres, Chassis	3.1 Tyre type, P = pneumatic, SE = superelastic 1)	P	P	P
	3.2 Tyre size, front	8.25X15-14PR	8.25X15-14PR	8.25X15-14PR
	3.3 Tyre size, rear	8.25X15-14PR	8.25X15-14PR	8.25X15-14PR
	3.5 Wheels, number front/rear (x = drive wheels)	4X/2	4X/2	4X/2
	3.6 Tread, front b10 (mm)	1575	1575	1575
	3.7 Tread, rear b11 (mm)	1610	1610	1610
Dimensions	4.1 Tilt of upright/fork carriage, α/β Grad	10/15	10/15	10/15
	4.2 Height, upright lowered h1(mm)	2650	2650	2650
	4.3 Freelift h2(mm)	110	110	110
	4.4 Lift height 2) h3(mm)	3300	3300	3300
	4.5 Height, upright extended 5) h4(mm)	4464	4464	4464
	4.7 Height overheadguard (cab); Std/Container h6(mm)	2370	2370	2370
	4.8 Seat height h7(mm)	1320	1320	1320
	4.12 Coupling height h10(mm)	470	470	470
	4.19 Overall length l1(mm)	4723	4783	4783
	4.20 Length to face of forks l2(mm)	3523	3583	3583
	4.21 Width b1, b2 (mm)	2125	2125	2125
	4.22 Fork dimensions s • e • l (mm)	60X150X1200	60X150X1200	60X180X1200
	4.23 Fork carriage DIN 15173, A, B	Shaft type	Shaft type	Shaft type
	4.24 Fork carriage width b3 (mm)	2040	2040	2040
	4.31 Ground clearance minimum m1 (mm)	200	200	200
	4.32 Ground clearance centre of wheelbase m2 (mm)	230	230	230
	4.33 Aisle width for pallets 1000 x 1200 crossways Ast(mm)	5250	5280	5280
4.34 Aisle width for pallets 800 x 1200 lengthways Ast(mm)	5450	5480	5480	
4.35 Turning radius (mm)	3420	3450	3450	
4.36 Internal turning radius b13 (mm)	1063	1063	1063	
Performances	5.1 Travel speed laden /unladen km/h	29.3/31.4	29.0/30.2	28.3/29.6
	5.2 Lift speed laden /unladen m/s	0.44/0.49	0.42/0.49	0.39/0.49
	5.3 Lowering speed laden /unladen m/s	0.45/0.43	0.45/0.43	0.45/0.43
	5.6 Max. drawbar pull laden/unladen 3) N	59841/23347	62784/22661	59448/22955
	5.8 Max. gradeability laden/unladen 3) %	41.0/21.4	42.2/20.0	38.4/20.0
	5.10 Service brake	Wet disc brake	Wet disc brake	Wet disc brake
I.C.-Engine	7.1 Manufacturer /Type 5)	GM/GM 4.3	GM/GM 4.3	GM/GM 4.3
	7.2 Rated output acc. DIN 70 020 kW	69	69	69
	7.3 Rated speed acc. DIN 70 020 min-1	2400	2400	2400
	7.4 No. of cylinders /displacement /cm3	6/4300	6/4300	6/4300
	7.5 Fuel consumption acc. VDI-CyclusDiesel = l/h, L.P.-Gas = kg/h	-	-	-
Misc.	8.1 Type of control	Hydrodyn.	Hydrodyn.	Hydrodyn.
	8.2 Operating pressure for attachments 5) bar	Adjustable	Adjustable	Adjustable
	8.3 Oil volume for attachments l/min	max. 35	max. 35	max. 35
	8.4 Sound level, driver's ear acc. EN 12053 dB (A)	82,7	82,7	82,7
	8.5 Towing coupling, class/type DIN	PIN	PIN	PIN

*1 Optional with super-elastic tyres *2 Further lift heights see upright table *3 At friction coefficient $\mu = 0.6$ *4 Diesel = Stage 3a / LPG = Stage 0 *5 Max.140 bar

Performance may vary +5% and -10% due to motor and system efficiency tolerance. The performance shown represents nominal values which may be obtained under typical operating conditions of a machine. CLARK products and specifications are subject to change without notice.

GENERAL DATA

Truck Capacities Capacity at different load centres

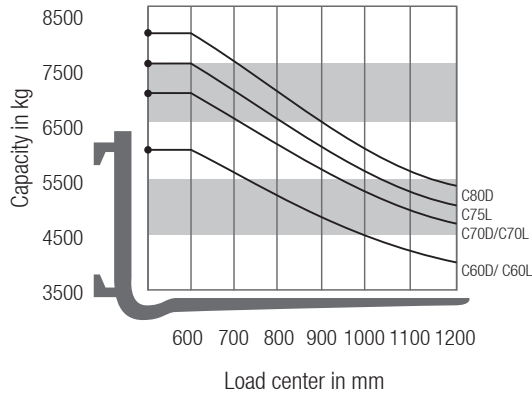

Note:

The listed capacities are valid only for the standard upright in vertical position with standard fork carriage and standard forks, up to max. lifting height of 3300 mm. The centre of gravity of the load may be displaced by max. 100 mm against the longitudinal centre plane of the truck. Load centre is determined from top and front face of the forks. The values are based on a 1000 mm cube load configuration with the centre of gravity at the true centre of the cube. With upright tilted forward lower capacity values are valid. Attachments, longer forks, exceptional load dimensions and higher lifting heights can reduce the capacity. Please talk to your CLARK dealer if you require further information.

Upright table C60D/C70D

Mast type	Maximum Fork Height (h3)	Mast		Free lift (h2)	
		Lowered (h1)	Extended		
	mm	mm	mm	mm	
Standard	2500	2250	3664	110	
	2700	2350	3864		
	3000	2500	4164		
	3300	2650	4464		
	3500	2750	4664		
	3700	2850	4864		
	4000	3000	5164		
	4500	3250	5664		
	5000	3500	6164		
	5500	3750	6664		
Triple	6000	4200	7164		
	6400	4400	7564		
	3850	2313	4980		1211
	4000	2363	5130		1261
	4500	2531	5634		1429
	4900	2665	6036		1563
	6200	3097	7332		1995
	7000	3363	8140	2261	
	8000	3695	9140	2593	

Upright table C60L/C70L/C75L

Mast type	Maximum Fork Height (h3)	Mast		Free lift (h2)	
		Lowered (h1)	Extended		
	mm	mm	mm	mm	
Standard	2500	2250	3664	110	
	2700	2350	3864		
	3000	2500	4164		
	3300	2650	4464		
	3500	2750	4664		
	3700	2850	4864		
	4000	3000	5164		
	4500	3250	5664		
	5000	3500	6164		
	5500	3750	6664		
Triple	6000	4200	7164		
	6400	4400	7564		
	3850	2313	4980		1211
	4000	2363	5130		1261
	4500	2531	5634		1429
	4900	2665	6036		1563
	6200	3097	7332		1995
	7000	3363	8140	2261	
	8000	3695	9140	2593	

Upright table C80D

Mast type	Maximum Fork Height (h3)	Mast		Free lift (h2)	
		Lowered (h1)	Extended		
	mm	mm	mm	mm	
Standard	2300	2226	3464	223	
	2500	2326	3664		
	2800	2476	3964		
	3100	2626	4264		
	3300	2726	4464		
	3500	2826	4664		
	3800	2976	4964		
	4300	3226	5464		
	4800	3476	5964		
	5300	3726	6464		
Triple	5800	3976	6964		
	6200	4176	7364		
	3650	2313	4790		1211
	3800	2363	4940		1261
	4300	2531	5444		1429
	4700	2665	5846		1563
	6000	3097	7142		1995
	6800	3363	7950	2261	
	7800	3695	8950	2593	

Performance may vary +5% and -10% due to motor and system efficiency tolerance. The performance shown represents nominal values which may be obtained under typical operating conditions of a machine. CLARK products and specifications are subject to change without notice.

PRODUCT DESCRIPTION



Drawing on the many years of manufacturing in the 6 to 8 ton range of forklifts, Clark offers with the C60-80 series the optimized collection of high quality components making for an extremely powerful truck. The combination of a capable efficient 55,4kW Deutz diesel engine, a fully automatic three speed gearbox and wet disc brakes as a standard together with a one piece robust frame makes this series extraordinary strong and tough. The low operating and maintenance costs as well as the ergonomic designed operator compartment are also highlights of this series of trucks. Exactly what you rightly can expect from a heavy duty truck produced by CLARK.

Driver's cab

The driver accesses his ergonomically designed compartment via two large, low positioned steps from either side of the machine. A grab handle on the driver's side of entry makes it easy to climb up and down without effort. A full width rubber floor covering in the footwell area prevents slippage. The adjustable steering column (30°) with two spoke steering wheel, an easy to adjust, comfortable operators seat, together with impressive leg room allow perfect adaptation to any driver. Automotive style foot pedals and fully directional hood mounted control levers marked with international symbols avoid confusion for any operator. A clear colour display ensures all operating data is available in real time. A low front cowl and ingenious narrow profile arrangement of the chains and hoses on the upright ensure a wide field of vision for the driver. Easily accessible storage compartments and an ideally positioned automotive style hand brake, set this driver's cab apart. Additionally this series offers protected storage compartments integrated in the vehicle frame.

Engine, Transmission

The CLARK C60-80 forklifts with LPG or diesel power offer excellent acceleration and high driving performance coupled with low fuel consumption. These extremely powerful modern engines are at the top end of the performance class. The 67kW Iveco 4.5 litre engine gives excellent power and good acceleration. The 6 cylinders GM 4.3L LPG engine with internal balancer runs very smoothly even under load. An Optional three-way exhaust catalyst converter is available for the LPG version. Both engines are connected to a fully automatic "Power-Shift" three speed transmission to make precise and comfortable working possible. The inch-pedal has an integrated brake function and enables controlled driving and braking during all lift operations. To protect your investment, the temperature of the engine and transmission is constantly monitored, ensuring that in the event of design limits being exceeded, the engine automatically switches off. A Heavy-Duty flexible coupling of the engine/transmission and drive axle reduces vibrations and noises to a minimum.

Brake system

All the trucks of this series have wet disc service brakes and an independent drum parking brake as standard. When the parking brake is applied, the transmission is placed in neutral to avoid any unintentional driving against the parking brake. The wet disc brakes have minimum abrasion, are maintenance free and allow very sensitive braking even with a heavy load. Power assisted foot brakes ensure a relaxed and stress free operation allowing the operator to work in a free manner with full focus on the task in hand. Remember, a stress free comfortable operator, works always at his peak ensuring optimum productivity over the complete shift.

Steering system

The hydrostatic power steering eliminates steering Kick-Back, makes steering easy and reaches full lock with just a few turns of the steering wheel. The steering axle has pivotal bearings mounted in rubber steel elements. The spherical bearing mounted short tie rods are adjustment free and guarantee precise and continuous driving in a straight line. The double acting steer cylinder ensures precise and direct steering. The axle king pins are mounted in lubricated tapered roller bearings for long service life.

Hydraulic system

A full-flow reverse filter, filters the oil to the tank at each reverse flow. Rough particles are filtered directly via a suction filter, thereby preventing them from entering the oil circuit, ensuring a long service life for all hydraulic components. Enough hydraulic oil is always available for all functions, because a high-capacity pump provides adequate oil supply for the upright and the hydrostatic steering. A priority distributor ensures steering priority in all conditions. Load handling is controlled via a load sensitive-response and precise control valve. A safety valve provides extra safety and prevents an uncontrolled lowering of the load at all times.

Upright

The clear-view uprights are available in Standard and Triplex versions. The heavy duty interlocked narrow profiles provide high strength even under the heaviest load. The canted (Angled) mounted rollers are adjusted or exchangeable without disassembling the upright. The tilt cylinders are mounted in spherical bearings allowing free movement. This consequently extends the service life of the complete cylinder. An integral tilt-lock valve prevents unintentional tilting of the upright when the power is off. The heavy duty tapered forged forks with hook or shaft mounting are adjustable and locked by individual pins. The sturdy 6-roller fork carriage with adjustable side thrust rollers enhances the durability of this design, preventing carriage "Jamming" when handling off-set loads.

Additional standard equipment

Protected front headlights, direction indicator lights, combination rear lights with brake lights and white reversing lights, pneumatic tyres, acoustic reversing alarm, paintwork in the bright safety colour "CLARK Green", driver's compartment and upright in black, rims in white.

Additional equipment

SE tyres, Forkpositioner, various cabin versions with optional air-condition (DSL only), integrated heating system or optional MP3-audiosystem, integrated or hook on sidsifts, mini-levers with armrest, quick-release couplings, various seats and much more.

Certification

The C60-80 series is CE certified and corresponds to all European safety standards for forklift trucks.

Talk to your CLARK dealer to find the optimum equipment for you.

CLARK Europe GmbH
Dr.-Alfred-Herrhausen-Allee 33
47228 Duisburg / Germany
Tel.: +49 (0)2065 499 13-0
Fax: +49 (0)2065 499 13-290
E-Mail: Info-europe@clarkmheu.com
www.clarkmheu.com

Официальный дилер: ООО «Форклифт»
Тел./факс: (499) 951-79-99 (многоканальный)
Екатеринбург: (343) 344-00-22; Пермь: (342) 294-40-49
Челябинск: (351) 211-54-25; Тюмень: (345) 238-28-26
E-mail: sales@forklift.ru, Web: www.forklift.ru
Skype: forklift-ural

Nr.: S0611E 08/2016
Lot Nr.: 9776/9826/9827/9776/9826/9827